

# HiTRON

## UNIVERSAL INPUT HARMONIC CORRECTION AC-DC OPEN FRAME AND ACTIVE CURRENT SHARING MULTI-OUTPUT 200 WATTS INTERNAL SWITCHING POWER SUPPLIES HVP200 SERIES



### FEATURES:

- ACCOMMODATE UNIVERSAL AC SOURCES
- MEET IEC 61000-3-2 HARMONIC CORRECTION
- THIRD-WIRE LOADING SHARING
- MEET UNIVERSAL SAFETY STANDARDS
- EMI MEET CISPR PUB.22 CLASS B
- +5V STAND-BY GREEN POWER
- CE MARKING COMPLIANCE

### SPECIFICATION

#### INPUT SPECIFICATION

**Input Voltage:** Typ. 90-264Vac with PFC.  
**Input Connector:** Molex #5273 V-M connector.  
**Input Frequency:** 47-63Hz.  
**Inrush Current:** Typ. 33A @230Vac.  
**Input Current:** 2.25A @115Vac, 1.0 A@230Vac.  
**Dielectric Withstand:** Meet IEC 60950-1.  
**EMI:** Meet CISPR PUB.22 Class B.  
**Hold-up Time:** 18mS @115Vac & 230Vac.  
**Power Fail Signal:** Installed.  
**DC OK Signal:** Installed in VO1 & VO2.  
**Power Factor Correction:** Meet Harmonic Correction per IEC 61000-3-2 PF typ. 0.97-0.99.  
**Remote Inhibit:** Installed. Enable active high.  
**Over Temperature Protection:** Thermostat @ 95°C.  
**Earth Leakage:** Less than 0.75mA.

#### OUTPUT SPECIFICATION

**Output Voltage:** See Ratings Chart.  
**Output Current:** See Ratings Chart.  
**Output Connector:** Molex #5273 V-M connector.  
**Output Wattage:** Convection 150 watts.  
 With 30 cfm forced air 200W.  
**Line Regulation:** Typ. 0.1%.  
**Load Regulation:** Main O/P VO1: Typ. ±1.0%.  
 Aux. O/P VO2: Typ. ±1.0%. (Magnetic Amp).  
 Aux. O/P VO3,4,5: Typ. ±2-3.0%. (P.R.).  
**Stand-By Green Power:** +5V/50mA available.  
**Noise & Ripple:** Typ. 1.0% peak to peak.  
**OVP:** Available at VO1 & VO2.  
**Remote Sense:** Installed in VO1 & VO2.  
**Adjustability:** Available at VO1 & VO2.  
**Load Sharing:** Active current sharing circuit at VO1.  
**Overload Protection (OLP):** Fully protected against output overload and short circuit.  
 Consult the factory for OLP setting.

#### GENERAL SPECIFICATION

**Efficiency:** Typ. 65-70%.  
**Switching Frequency:** Fixed frequency at 70K Hz.  
**Circuit Topology:** PWM fixed-frequency forward circuit.  
**Transient Response:** Output voltage returns in less than 3mS following a 25% load change.  
**Safety Standard:** UL 60950-1/EN 60950-1 Class I.  
**Power Density:** 3.0 Watts / Cubic Inch.  
**Operating Temperature:** 0 to +50°C under forced air flow for full load.  
**Storage Temperature:** -20 to +85°C.  
**Temperature Coefficient:** Typ. ±0.04%/°C.  
**Cooling:** 30 cfm air flow is required to deliver the full power 200W.  
**Construction:** U-bracket construction format.

Note: Due to requests in market and advances in technology, specifications subject to change without notification.



For the details of safety approval, please consult the factory.

# OUTPUT VOLTAGE / CURRENT RATINGS CHART

## DUAL OUTPUT (Under forced air cooling)

MODEL NO.	MAIN VO1 @★#≡		AUX. +VO2 @★#▲	
	Typ.	Volt.	Typ.	Volt.
HVP200-20	25.0A	+5.0V	10.0A	+5.0V
HVP200-21	25.0A	+5.0V	5.0A	+12.0V
HVP200-22	25.0A	+5.0V	4.0A	+15.0V
HVP200-23	25.0A	+5.0V	2.5A	+24.0V
HVP200-290A	25.0A	+5.0V	15.0A	+3.3V
HVP200-290B	30.0A	+3.3V	15.0A	+5.0V
HVP200-291	30.0A	+3.3V	5.0A	+12.0V
HVP200-292	30.0A	+3.3V	4.0A	+15.0V
HVP200-293	30.0A	+3.3V	2.5A	+24.0V

## TRIPLE OUTPUT (Under forced air cooling)

MODEL NO.	MAIN VO1 @★#≡		AUX. VO2 @★#▲		AUX. VO3 ◇■●	
	Typ.	Volt.	Typ.	Volt.	Typ.	Volt.
HVP200-30	25.0A	+5.0V	4.0A	+12.0V	1.0A	12.0V
HVP200-31	25.0A	+5.0V	4.0A	+12.0V	2.0A	5.0V
HVP200-32	25.0A	+5.0V	10.0A	+3.3V	1.0A	12.0V
HVP200-33	25.0A	+5.0V	10.0A	+3.3V	1.0A	15.0V

## QUAD OUTPUT (Under forced air cooling)

MODEL NO.	MAIN VO1 @★#≡		AUX. VO2 @★#▲		AUX. VO3 ◇■●		AUX. VO4 ◇■●	
	Typ.	Volt.	Typ.	Volt.	Typ.	Volt.	Typ.	Volt.
HVP200-40	20.0A	+5.0V	4.0A	+12.0V	3.0A	12.0V	3.0A	12.0V
HVP200-41	20.0A	+5.0V	4.0A	+12.0V	3.0A	5.0V	3.0A	5.0V
HVP200-42	20.0A	+5.0V	2.0A	+24.0V	3.0A	12.0V	3.0A	12.0V
HVP200-43	20.0A	+5.0V	3.5A	+15.0V	3.0A	12.0V	3.0A	12.0V
HVP200-490A	20.0A	+5.0V	15.0A	+3.3V	3.0A	12.0V	3.0A	12.0V
HVP200-490B	20.0A	+3.3V	15.0A	+5.0V	3.0A	12.0V	3.0A	5.0V
HVP200-491A	20.0A	+5.0V	15.0A	+3.3V	2.5A	15.0V	2.5A	15.0V
HVP200-491B	20.0A	+3.3V	15.0A	+5.0V	2.5A	15.0V	2.5A	15.0V

## PENTAD OUTPUT (Under forced air cooling)

MODEL NO.	MAIN VO1 @★#≡		AUX. VO2 @★#▲		AUX. VO3 ◇■●		AUX. ◇VO4 ■●		AUX. VO5 ■●	
	Typ.	Volt.	Typ.	Volt.	Typ.	Volt.	Typ.	Volt.	Typ.	Volt.
HVP200-590	20.0A	+3.3V	12.0A	+5.0V	1.0A	12.0V	1.0A	12.0V	1.0A	+15.0V
HVP200-591	20.0A	+3.3V	5.0A	+12.0V	1.0A	12.0V	1.0A	12.0V	2.0A	+5.0V
HVP200-592	20.0A	+3.3V	12.0A	+5.0V	1.0A	15.0V	1.0A	15.0V	1.0A	+12.0V
HVP200-593	8.0A	+3.3V	5.0A	+12.0V	3.0A	12.0V	3.0A	12.0V	2.0A	+5.0V

Symbol: "★" OVP built-in. "@" Adjustable. "■" Couple filter inductor. "#" Remote sensing. "◇" Floating (or isolated) output.  
 "●" Installed with Post Regulator (P.R.). "▲" Installed with magnetic amplifier. "≡" Active current sharing.

## MECHANICAL DIMENSIONS: MM [INCHES]

WEIGHT: 1,164.0g (41.0 Oz.)

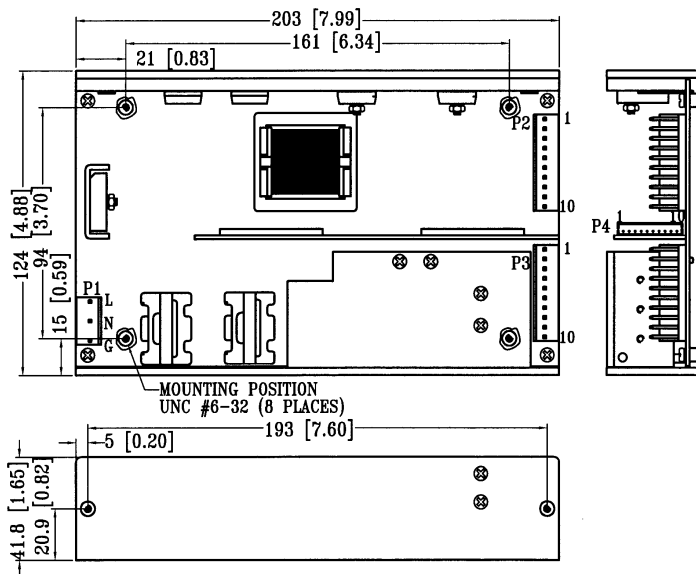

## INPUT & OUTPUT CONNECTORS PIN ASSIGNMENT

ASSIGNMENT	AC INPUT			DUAL/TRIPLE/QUAD/PENTAD OUTPUT								ASSORTED SIGNALS									
	AC-L	AC-N	AC-G	+VO1	DC-COM	VO2	VO5	VO3	VO4	-VO3	-VO4	DC-COM	Enable	Power Fail	DC-OK	+5V S.B.	VO1 +S	VO1 -S	VO1 ≡	VO2 +S	VO2 -S
CNTR & PIN#	P1-L	P1-N	P1-G	P2-1, 2, 3	P2-4, 5, 6, 7	P2-8, 9, 10	P3-1,2	P3-3,4	P3-9, 10	P3-5,6	P3-7,8	P4-5	P4-3	P4-1	P4-2	P4-4	P4-7	P4-8	P4-6	P4-10	P4-9

Mating connector: P1,2,3 Molex # 5195 or 5239 series.  
 P4 Molex # 5264 series or equivalent.